

ISOMAG

The friendly magmeter

DATA SHEET

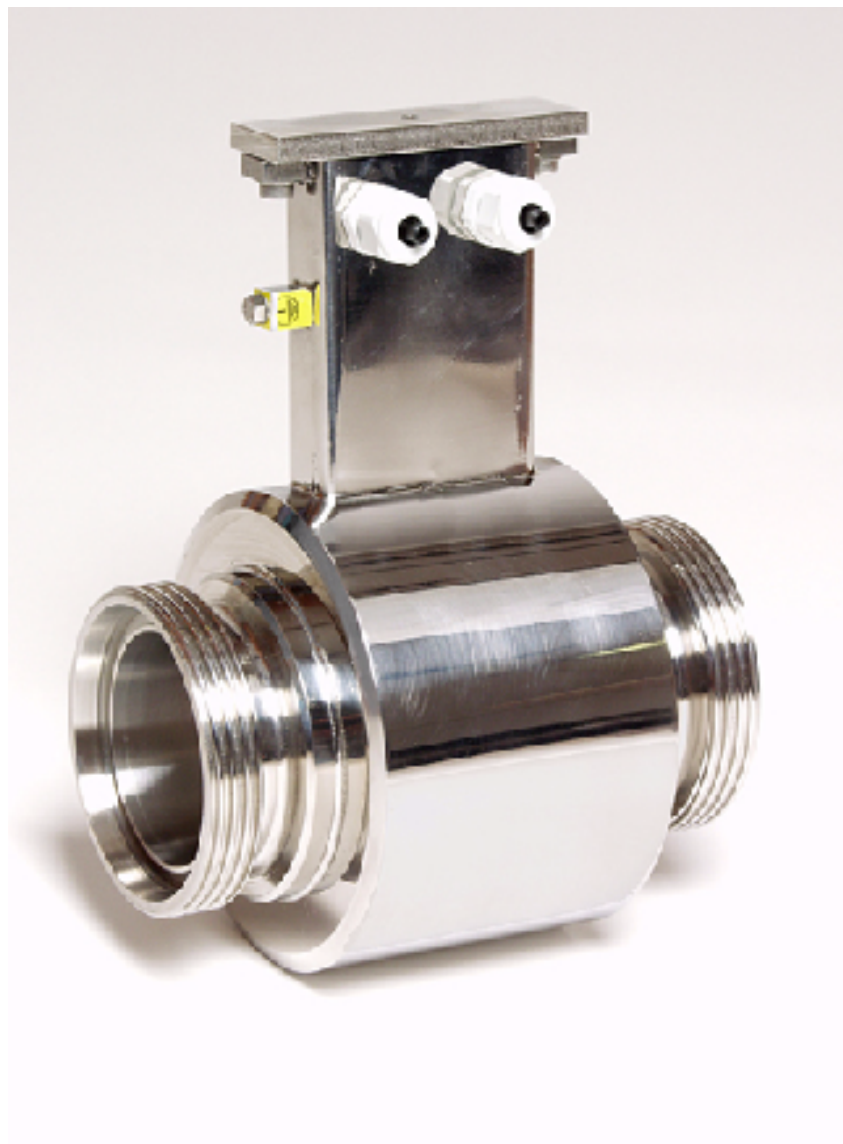

MS 2410

CE

ISOIL 
INDUSTRIA



INDEX

TECHNICAL DATA	2
OVERALL FEATURES	2
STANDARD FEATURES	2
DIN/SMS FITTINGS	3
CLAMP FITTINGS	4
INSTALLATION RECOMMENDATIONS	5
SENSOR GROUNDING	6
SEPARATE VERSION	6
PRESSURE LOSS CALCULATION (CONES 8° ANGLES)	7
HOW TO ORDER	8

The manufacturer guarantees only English text available on our web site www.isoli.com

TECHNICAL DATA**OVERALL FEATURES**

Nominal diameter	<input type="checkbox"/> DN 3 ÷ 100
Minimum conductivity	<input type="checkbox"/> 5 µS/cm
Humidity Range	<input type="checkbox"/> 0÷100% (IP 67)
Accuracy	<input type="checkbox"/> See relevant converter data sheet
CE Certification	<input type="checkbox"/> Yes

STANDARD FEATURES

Body material	<input type="checkbox"/> Stainless steel AISI 304
Nominal pressure	<input type="checkbox"/> 1600 KPa
Process connection	<input type="checkbox"/> DIN 11851 <input type="checkbox"/> Tri-clamp ® <input type="checkbox"/> Tri-clover® <input type="checkbox"/> SMS 1146 <input type="checkbox"/> Other on request
Version – protection rating	<input type="checkbox"/> Compact IP67
Connection material	<input type="checkbox"/> Stainless steel AISI 316
Lining material	<input type="checkbox"/> PTFE
Gasket material	<input type="checkbox"/> FPM
Liquid temperature	<input type="checkbox"/> -20 °C ÷ +100 °C comp. version. (130 °C only with ML4F-1) <input type="checkbox"/> -20 °C ÷ + 150 °C separate version.
Vacuum resistance	<input type="checkbox"/> 20 Kpa at 100 °C
Electrodes material	<input type="checkbox"/> Stainless steel AISI 316L

OPTIONAL FEATURES**(CHECK FOR MORE DETAILS 'HOW TO ORDER' ON LAST PAGE)**

Body material	<input type="checkbox"/> Stainless steel AISI 316
Gasket material	<input type="checkbox"/> EPDM
Process connection	<input type="checkbox"/> Others on request
Electrodes material	<input type="checkbox"/> On request
Version – protection rating	<input type="checkbox"/> Separate version (max 20m) – IP 68 <input type="checkbox"/> Separate version (max 500 m), with preamplifier – IP 67 (OPT. IP 68)

DIN/SMS FITTINGS

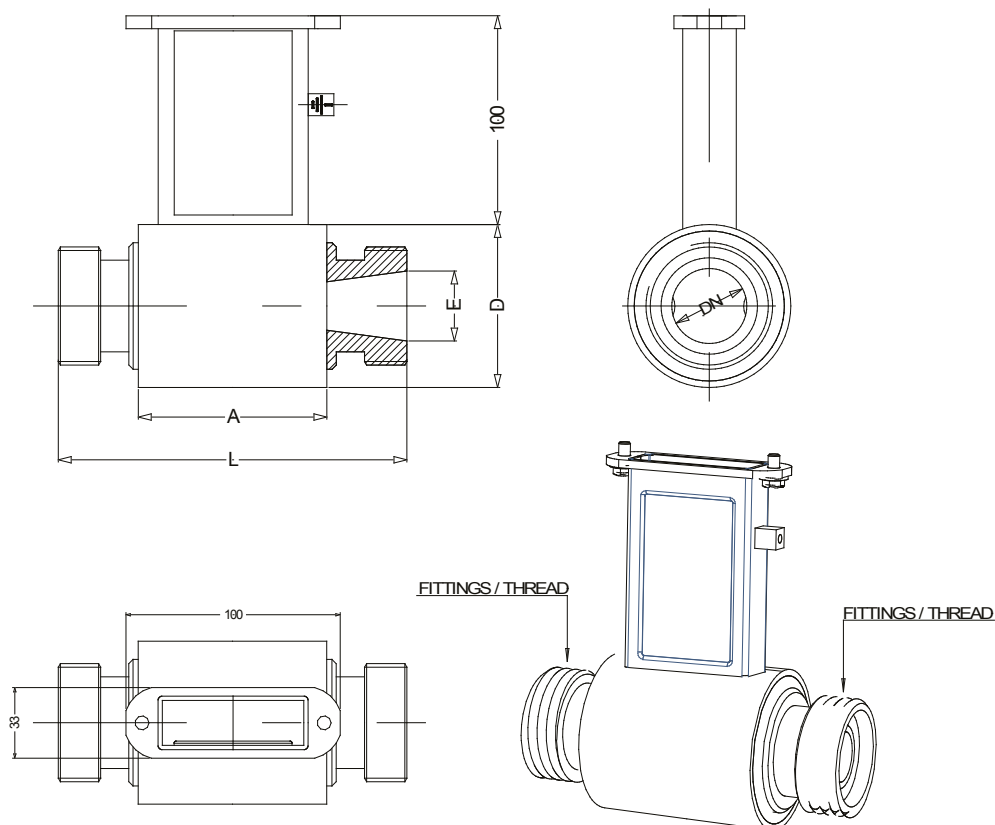

DIN 11851

DIMENSIONS mm (inches)	DN											
	3 (1/8")	6 (1/4)	10 (3/8)	15 (1/2")	20 (3/4")	25 (1")	32 (1"1/4)	40 (1"1/2)	50 (2")	65 (2"1/2)	65 (2"1/2)	100 (4")
A	77 (3.03)	77 (3.03)	77 (3.03)	77 (3.03)	77 (3.03)	100 (3.94)	100 (3.94)	100 (3.94)	100 (3.94)	100 (3.94)	100 (3.94)	100 (3.94)
L	128 (5.04)	128 (5.04)	128 (5.04)	128 (5.04)	128 (5.04)	180 (7.09)	180 (7.09)	180 (7.09)	180 (7.09)	180 (7.09)	200 (7.87)	200 (7.87)
D	76 (3)	76 (3)	76 (3)	76 (3)	76 (3)	76 (3)	89 (3.50)	89 (3.50)	114 (4.49)	140 (5.51)	140 (5.51)	168 (6.61)
E	10 (0.39)	10 (0.39)	10 (0.39)	16 (0.63)	20 (0.79)	26 (1.02)	32 (1.26)	38 (1.49)	50 (1.97)	66 (2.60)	81 (3.19)	100 (3.94)
Thread	RD28-8	RD28-8	RD28-8	RD34-8	RD44-6	RD52-6	RD58-6	RD65-6	RD78-6	RD95-6	RD110-4	RD130-4
FITTINGS	DN 10	DN 10	DN 10	DN 15	DN 20	DN25	DN 32	DN 40	DN 50	DN 65	DN 80	DN 100

SMS 1146

DIMENSIONS mm (inches)	DN									
	10 (3/8)	15 (1/2")	20 (3/4")	25 (1")	40 (1"1/2)	50 (2")	65 (2"1/2)	80 (3")	100 (4")	
A	77 (3.03)	77 (3.03)	77 (3.03)	100 (3.94)	100 (3.94)	100 (3.94)	100 (3.94)	100 (3.94)	100 (3.94)	
L	128 (5.04)	128 (5.04)	128 (5.04)	180 (7.09)	180 (7.09)	180 (7.09)	180 (7.09)	200 (7.87)	200 (7.87)	
D	76 (3)	76 (3)	76 (3)	76 (3)	89 (3.50)	114 (4.49)	140 (5.51)	140 (5.51)	168 (6.61)	
E	22.6 (0.89)				36.8 (1.45)	49.3 (1.94)	58.3 (2.29)	70.7 (2.78)	95.7 (3.77)	
Thread	RD40-6			Rd 40-6	Rd 60-6	Rd 70-6	Rd 85-6	Rd 98-6	Rd 140-4	
FITTINGS	DN 25	DN 25	DN 25	DN25	DN 38	DN 51	DN 63	DN 76	DN 104	

CLAMP FITTINGS

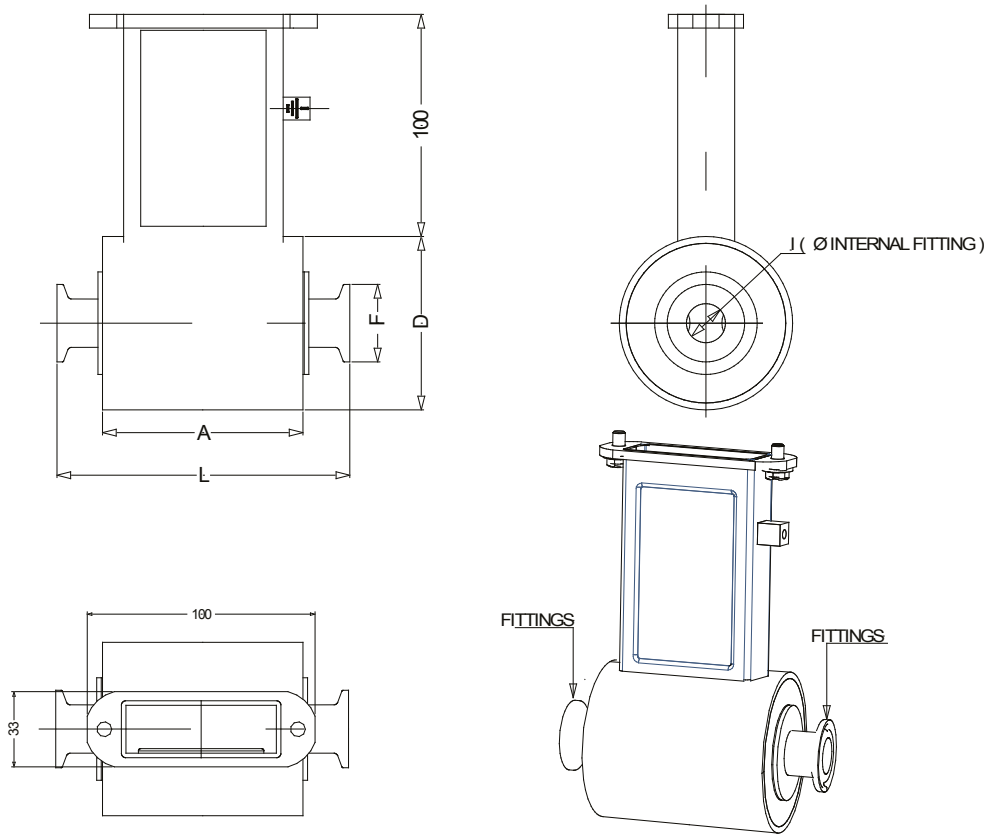

CLAMP ISO 2852

DIMENSIONS mm (inches)	DN										
	3 (1/8")	6 (1/4)	10 (3/8)	15 (1/2")	20 (3/4")	25 (1")	40 (1 1/2)	50 (2")	65 (2 1/2)	80 (3")	100 (4")
A	77 (3.03)	77 (3.03)	77 (3.03)	77 (3.03)	77 (3.03)	100 (3.94)	100 (3.94)	100 (3.94)	100 (3.94)	100 (3.94)	100 (3.94)
L	128 (5.04)	128 (5.04)	128 (5.04)	128 (5.04)	128 (5.04)	180 (7.09)	180 (7.09)	180 (7.09)	180 (7.09)	200 (7.87)	200 (7.87)
D	76 (3)	76 (3)	76 (3)	76 (3)	76 (3)	76 (3)	89 (3.50)	114 (4.49)	140 (5.51)	140 (5.51)	168 (6.61)
I	12.7 (0.5)	12.7 (0.5)	12.7 (0.5)	17.2 (0.68)	21.3 (0.84)	22.6 (0.89)	35.6 (1.40)	48.6 (1.91)	60.3 (2.37)	72.9 (2.87)	97.6 (3.84)
F	34 (1.34)	34 (1.34)	34 (1.34)	34 (1.34)	34 (1.34)	50.5 (1.99)	50.5 (1.99)	64 (2.52)	77.5 (3.05)	91 (3.58)	119 (4.69)

CLAMP BS 4825 Part 3

DIMENSIONS mm (inches)	DN										
	3 (1/8")	6 (1/4)	10 (3/8)	15 (1/2")	20 (3/4")	25 (1")	40 (1 1/2)	50 (2")	65 (2 1/2)	80 (3")	100 (4")
A	77 (3.03)	77 (3.03)	77 (3.03)	77 (3.03)	77 (3.03)	100 (3.94)	100 (3.94)	100 (3.94)	100 (3.94)	100 (3.94)	100 (3.94)
L	128 (5.04)	128 (5.04)	128 (5.04)	128 (5.04)	128 (5.04)	180 (7.09)	180 (7.09)	180 (7.09)	180 (7.09)	200 (7.87)	200 (7.87)
D	76 (3)	76 (3)	76 (3)	76 (3)	76 (3)	76 (3)	89 (3.50)	114 (4.49)	140 (5.51)	140 (5.51)	168 (6.61)
I	9.5 (0.37)	9.5 (0.37)	9.5 (0.37)	15.85 (0.62)	22.2 (0.87)	22.2 (0.87)	34.9 (1.37)	47.6 (1.87)	60.3 (2.37)	73 (2.87)	97.6 (3.84)
F	25.4 (1)	25.4 (1)	25.4 (1)	25.4 (1)	50.5 (1.99)	50.5 (1.99)	50.5 (1.99)	64 (2.52)	77.5 (3.05)	91 (3.58)	119 (4.69)

The manufacturer guarantees only English text available on our web site www.isoil.com

INSTALLATION RECOMMENDATIONS

In vertical installations an ascending flow is preferable. For vertical installations with descending flow direction contact the manufacturer

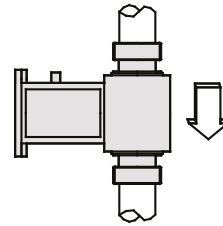
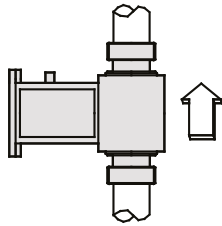

For installations in long pipe lines, please use anti vibration joints

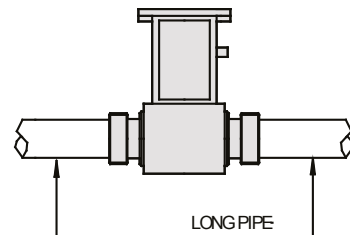
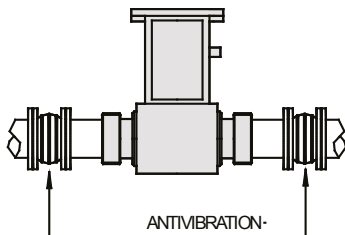

Avoid a partially empty pipe, during operation the pipe must be either completely full of liquid or completely empty

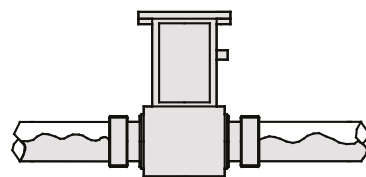
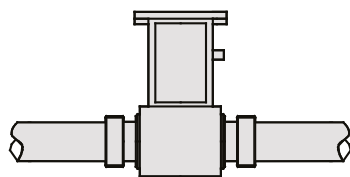

Install the sensor away from bends and hydraulic accessories

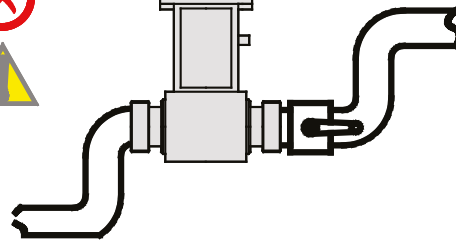
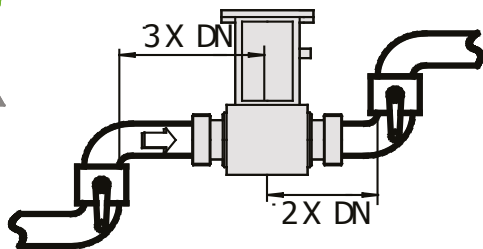

Avoid positioning fittings by tightening the damps.

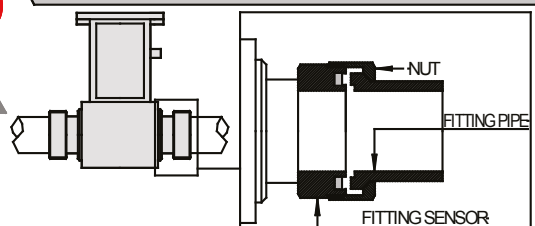
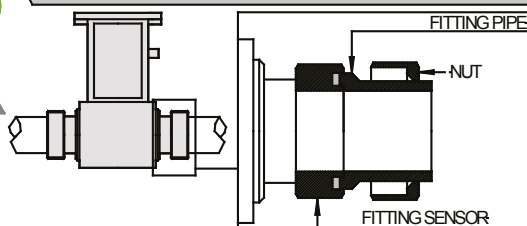

SENSOR GROUNDING

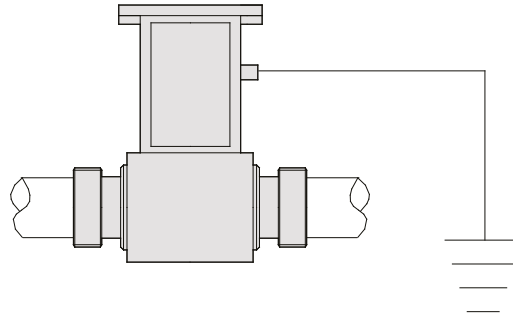

For the correct operation of the meter the sensor and liquid must be equipotential. ALWAYS connect sensor and converter to the ground.

SEPARATE VERSION

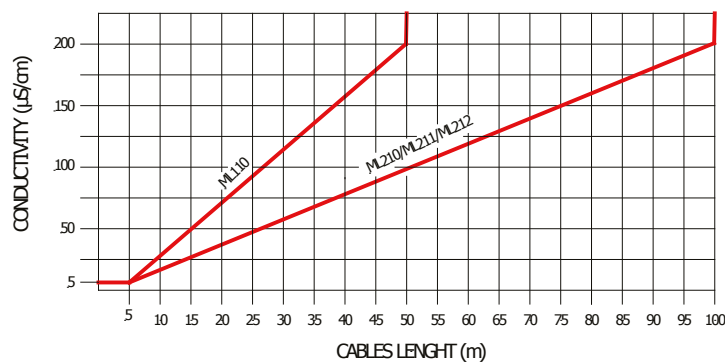
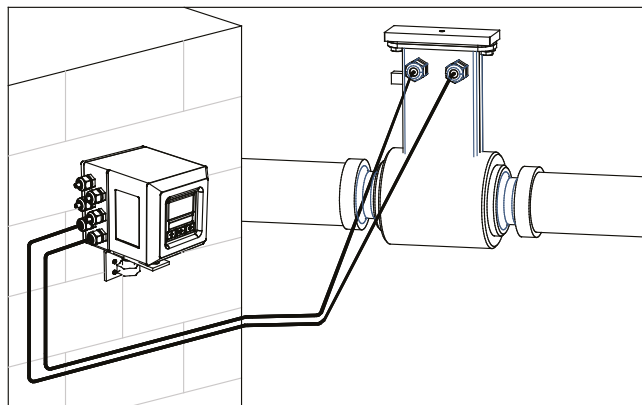

Notes:

- ❑ It is recommended to install the connection cables away from, or protect against sources of electromagnetic noise.
- ❑ The minimum conductivity of the liquid medium to ensure correct functionality of the empty pipe detection is 20 µS/cm.

PRESSURE LOSS CALCULATION (CONES 8° ANGLES)

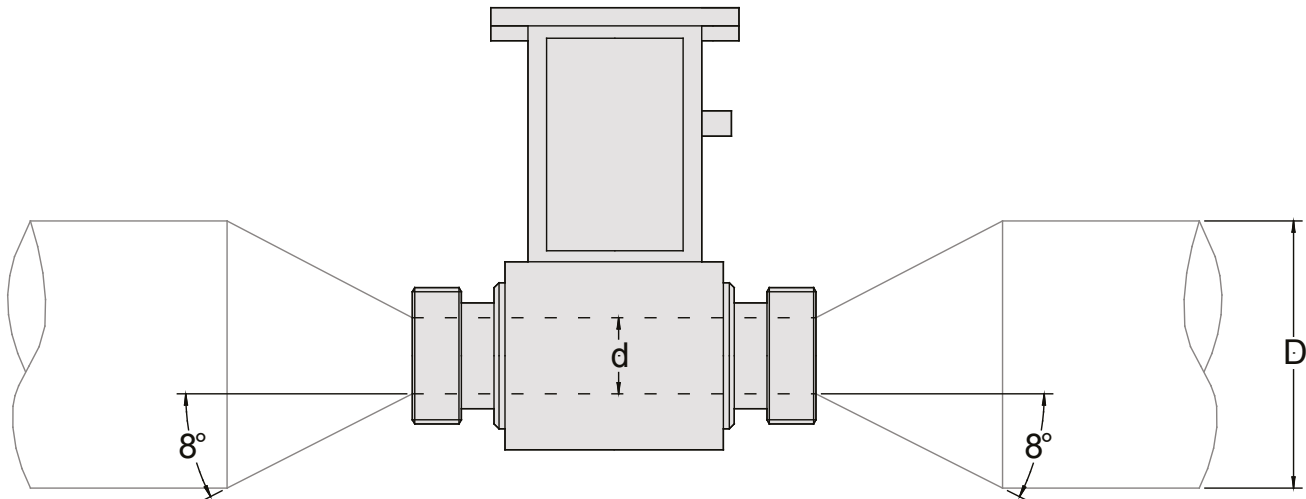

$$\Delta p = \left[0.10 + 0.20 \left(\left(\frac{d}{D} \right)^{-2} - 1 \right)^2 \left(\frac{d}{D} \right)^4 \right] \left(\rho \frac{u^2}{2} \right)$$

Dove:

Δp = Pressure loss in [Pa]

ρ = Fluid density [kg/m³] typical value $\rho = 1000$ [kg / m³]

d = sensor diameter [m]

D = pipe diameter (greater than sensor diameter) [m]

u = Mean flow velocity in sensor diameter [m/s]

Calculation examples Δp [mbar]

d/D \ u	1 [m/s]	2 [m/s]	3 [m/s]	4 [m/s]	5 [m/s]	6 [m/s]	7 [m/s]	8 [m/s]
0.5	1.1	4.3	9.6	17.0	26.6	38.3	52.1	68.0
0.6	0.9	3.6	8.2	14.6	22.7	32.7	44.6	58.2
0.7	0.8	3.0	6.8	12.2	19.0	27.4	37.2	48.6
0.8	0.6	2.5	5.7	10.1	15.7	22.7	30.9	40.3
0.9	0.5	2.1	4.8	8.6	13.4	19.3	26.3	34.3

Note:

- $\rho = 1000$ [kg / m³] as goodness approximation of water density in common use..
- Inner diameter of sensor is used for d , express in meters.
- Indeed pressure loss equation is dimensionally correct in [Pa]. The equation results in table are show in [mbar].

HOW TO ORDER

MS 2410		
EXAMPLE CODE	Nominal Diameter / Measuring range	
T03	T03	DN3 (1/8 "), measuring range 0.. 10.3 / 0...259 l/h
	T06	DN6 (1/4 "), measuring range 0...41.4/0...1037 l/h
	T10	DN10 (3/8 "), measuring range 0..115.2/0...2880 l/h
	T15	DN15 (1/2 "), measuring range 0.. 259.2/0...6480 l/h
	T20	DN20 (3/4 "), measuring range 0.. 460.8/0...11520 l/h
	T25	DN25, measuring range 0 ... 0,7 / 0 ... 18 m3/h
	T32	DN32, measuring range 0 ... 1,2 / 0 ... 29 m3/h
	T40	DN40, measuring range 0 ... 1,9 / 0 ... 46 m3/h
	T50	DN50, measuring range 0 ... 2,9 / 0 ... 72 m3/h
	T65	DN65, measuring range 0 ... 4,9 / 0 ... 122 m3/h
	T80	DN80, measuring range 0 ... 7,5 / 0 ... 184 m3/h
T100	DN100, measuring range 0 ... 11,7 / 0 ... 288 m3/h	
Gasket material (internal tightness)		
2	2	O-Ring : Epdm
	3	O-Ring : FKM (FDA1770)
	9	O-Ring : da specificare
Process connection type		
A	A	DIN11851-852 sanitary connection (*)
	B	Tri-Clamp connection, ISO2852
	C	SMS-1146 connection (**)
	D	Attacchi tri-clamp GB special connections
	E	Tri-Clamp connection, BS 4825 – Part 3
	Z	Connection: Others (***)
Number and electrodes material		
1	1	n. 2 measure electrodes in AISI316
	0	Electrode material: to be specified
Number and electrodes material		
A	A	Compact execution, IP67 protection rate
	K	Separate version, AISI 304 JB POLISCHED, protection rate IP68, standing immersion with 1,5 m of head water - (DEFINE THE CABLE LENGHT - ADD THE COST)

MS2410-T03-2A1A (Complete code example for order)

(*) : Use suitable gasket for cleaning in place (CIP) applications

(): With this option the process connection is only suitable for cleaning out of place (COP)**

(*) : Not available with 3-A marking**

Due to the constant technical development and improvements of its products, the manufacturer reserves the right to make changes and / or modify the information contained in this document without notice. Information contained herein is not binding.

ISOIL INDUSTRIA S.p.A.

HEAD OFFICE	SERVICE
Via Fratelli Gracchi, 27 20092 Cinisello Balsamo (MI) Tel +39 02 66027.1 Fax +39 02 6123202 vendite@isoil.it	isomagservice@isoil.it

If you want to find the complete list of our distributors access at the following link:
http://www.isoil.com/u_vendita.asp



Due to the constant technical development and improvement of its products, the manufacturer reserves the right to make changes and/or modify the information contained in this document without notice.

AZIENDA CON SISTEMA
DI GESTIONE QUALITÀ
CERTIFICATO DA DNV-GL
= ISO 9001 =

Locally available from

ANSAC

35, Marsiling Industrial Estate Road 3, #02-01 Singapore 739257
T: (65) 6368 0225 F: (65) 6368 8023
E: sales@ansac-tech.com.sg | www.ansac-tech.com.sg

ISOIL 
INDUSTRIA
The solutions that count